

Installation Manual



Oreco Systems®
Incorporated

814 AIRWAY AVENUE
SUTHERLIN, OREGON
97479-9012

TELEPHONE:
(541) 459-4449

FACSIMILE:
(541) 459-2884

VeriComm Control Panel VCOM-S1 PTRO Manual# EIN-CP-S-658

This Manual Contains:

Description	Document Number
1. VCOM Panel Installation Instructions	EIN-CP-GEN-4
2. Panel Wiring Diagram	EDW-WD-S-150
3. Float Arrangement & Splice Box Wiring Diagram	EDW-FS-S-2
4. VCOM-S PTRO Operation	EIN-CP-OP-504

VCOM Panel Installation

This document contains general installation instructions for VeriComm[®] control panels. Consult all supplemental documents (Control Panel Wiring Diagram, Float Arrangement Diagram, etc.) before installation. Follow the outlined sequence below.

1 Getting Started

Read all instructions before proceeding with the installation. Improper installation may void warranties.

1. Inspect your order for completeness and inspect each component for shipment damages. If something is missing or damaged, contact your supplier to obtain replacement parts.
2. Check to ensure the instructions and items supplied conform to state and local regulations.
3. A qualified electrician must be employed to install and service the panel and ancillary wiring. The equipment must be installed in compliance with the National Electric Code, as well as state and local codes.



The VCOM panels are part of the VeriComm product line, and work in conjunction with the VeriComm[®] Monitoring System.

2 Control Panel Placement

1. Physical installation of the control panel should be within view of the septic tank and located at a convenient height (about five feet above grade).
2. The panel should be securely fastened to a 4 x 4 post that has been concreted into the ground. Alternatively, the panel can be fastened to an exterior wall, subject to the restrictions below:
 - If the panel contains motor contactors, a thumping sound can be heard each time the pump is started or stopped. Therefore, *these panels should not be mounted on an exterior wall unless it is in a location away from living areas, such as on a garage wall.*
3. If possible, position the panel in the shade to protect it from weather. Extreme temperatures can cause inconsistent performance of the electrical components.
4. Check state and local electrical codes for proper placement of panels. Ensure that access to the panel is not obstructed.

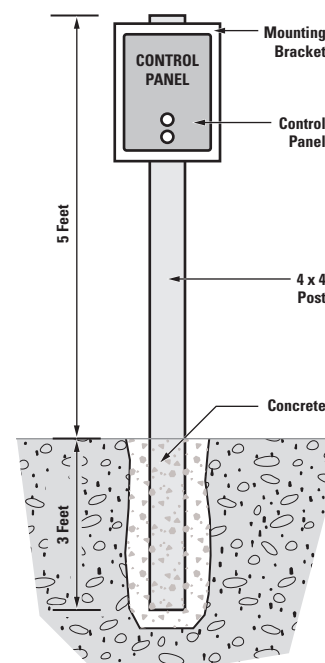

3 Float and Pump Installation

1. Install the electrical splice boxes for the floats and pumps before installing the actual floats and pumping equipment. The splice boxes are installed near the top of the riser, using the grommets provided.
2. Install the floats. Thread the float and pump cords through the cord grips into the PVC splice box, leaving adequate length of electrical cord coiled inside the riser to allow easy removal of the pump and float assembly.
3. Tighten the cord grips, using hand pressure or a wrench if necessary, until the cord will no longer move in the cord grip. If the cord grips are not tight enough, the seal will not be watertight, but over-tightening may damage the cord or the cord grip, so use only as much force as necessary.
4. Run the wires from the control panel to the splice box. The wires can be brought through a conduit, or can be buried using suitable direct-burial wire. Conduit that enters the splice box must be sealed, even if the wires are direct-buried, to prevent the infiltration of water into the splice box. Use an electrically approved sealant to plug the wires coming in through the conduit hub. The number of wires required depends on the control panel and the number of floats and pump(s) used.

Consult the appropriate float arrangement diagram for the control panel and float arrangement being used.

Wire should be sized at 14 AWG for the floats. Refer to the figure below to determine the proper size for the pump wires. When calculating wire size, the length and size of your branch circuit wires from the service entrance panel to the pump control panel must also be taken into account.

Recommended Breaker & Wire Size

Pump Motor Size	Breaker Size	Wire Size	Max Distance*
120 VAC 1/2 hp	20 amp	10 AWG	105 ft
240 VAC 1/2 hp	15 amp	14 AWG	161 ft
3/4 hp	20 amp	14 AWG	130 ft
1 hp	20 amp	12 AWG	172 ft
1-1/2 hp	20 amp	12 AWG	126 ft

* This is the maximum distance from this sub-panel to the pump motor for the recommended wire size. Distance is based on 3% maximum voltage drop from sub-panel to load at maximum recognized pump motor amps at 75° C.

5. All splices made in the splice box should use waterproof wire nuts or butt connectors and heat shrink tubing. Refer to Drawing EIN-SB-SB-1 for instructions on making waterproof splices. Refer to the appropriate float arrangement diagram for instructions on how to connect the floats together.

Note

- Do not remove the colored markers or the paper tags from the float cords. These should be left on the float cord, outside the splice box.
- Do not thread the markers and tags through the cord grips.
- Adequate length of cord should be left within the splice box to allow for easy removal for future disconnecting and re-splicing.
- A cord is secure and the connection watertight when the cord grip is tight enough to prevent slippage.
- Wire that is improperly sized (too small) can cause excessive voltage drop and poor pump performance.
- Splices that are not waterproof may cause a malfunction of the pump controls if water should leak into the splice box.

4 Control Panel Connections

1. Connect the wires coming from the floats to the terminals in the control panel. Refer to the appropriate float arrangement diagram for the correct terminal connections for your system.
2. Connect the wires coming from the pumps to the pump terminals. Refer to the panel wiring diagram for the correct terminal connections for your system.
3. Connect the incoming power to the panel. Power to the panel must be appropriate to the control panel and pump motor (120 VAC, single-phase for a 120 VAC motor, 240 VAC single-phase for a 240 VAC motor, etc.).
4. Ensure that the panel is properly grounded and that the fuse or breaker and wire size, from the main power panel and to the pump, are correctly sized. A separate circuit for the pump controls and each of the pump motors is recommended.

NOTE: Voltage for the controls in the panel is always 120 VAC, although the pump voltage may be 120 VAC or 240 VAC.

5. Use 60° minimum CU conductors only. Torque the terminal blocks to 15 LB-IN and the ground lugs to 45 LB-IN. Torque the circuit breakers to 20 LB-IN for 14-10 AWG wire, 25 LB-IN for 8 AWG wire, and 27 LB-IN for 6-4 AWG wire.

5 Telephone Line Installation

The VeriComm control panels utilize a common phone line with the homeowner. These panels do not require a dedicated phone line.

1. Install a standard analog line from the homeowner's phone splice box to the VeriComm control panel.

Recommended Part:

Outdoor 4-conductor phone cable

Radio Shack Cat. #: 278-386

2. If an RJ-11 crimping tool is available, crimp an RJ-11 plug directly to the phone wire. Connect the phone line to the jack on the surge arrester/DSL filter in the panel.

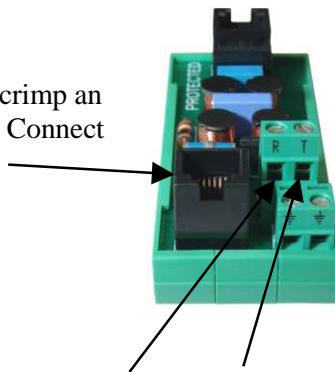

3. If an RJ-11 crimping tool is NOT available, the red and green phone wire can be terminated at terminals "R" and "T". The red wire should be connected to "R" and the green to "T".

WARNING ▲

Do not service the pump or any electrical wiring in the pump vault without disconnecting the power at the circuit breaker and/or fuse.

Serious injury and/or damage to the system could result if the panel is not properly grounded. Ensure that the fuse, breaker, and wire size—from the main power panel and to the pump—are sized correctly.

The pump vault is a hazardous area and may contain explosive gases. Take appropriate precautions according to local, state, and federal regulations before commencing work in the pump vault.

It is the responsibility of the installer to comply with all local, state, and federal regulations that may govern the installation of systems of this nature. Failure to comply with such regulations may void the manufacturer's warranty and could possibly cause bodily injury.

Note ◆

- Phone wires should not be run in the same conduit as power wires.
- The phone line surge arrester / DSL filter requires a good connection to ground to be effective. Ensure that this sub-panel is effectively grounded to the service panel.

Control Panel Wiring Diagram

Model VCOM-S1 PTR0

Key

- = Factory Wire
- - - = Field Wire
- · - · = Alternate Field Wire
- A = Audio Alarm, 115 VAC
- AL = Alarm Light
- AS = Audio Silence Switch
- CCB = Controls Circuit Breaker
- DF = Fuse, 120VAC/1A
- M = Motor Contactor
- PCB = Pump Circuit Breaker
- PSA = Phone Line Surge Arrestor
- RTU = ATRTU-100 Controller
- TL = Terminal Link
- TR = Transformer 120-36/18VAC

*Options

- HT = Heater
- PL = Power Light
- PRL = Pump Run Light
- SA = Surge Arrester

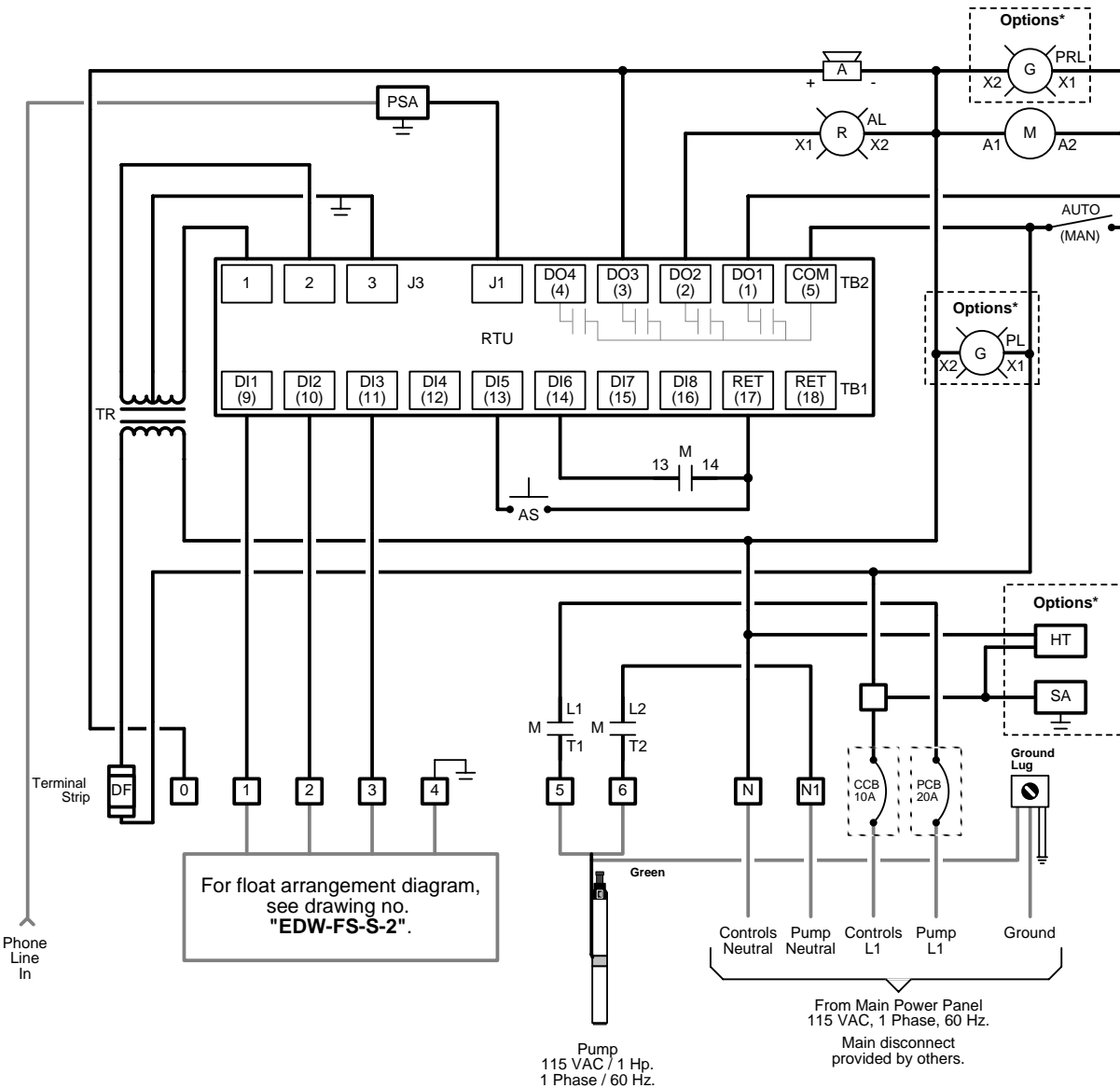

For float arrangement diagram, see drawing no. "EDW-FS-S-2".

NOTE: Motors must have internal overload protection

For VCOM-S PTR0 operation description, see drawing no. "EIN-CP-OP-504".

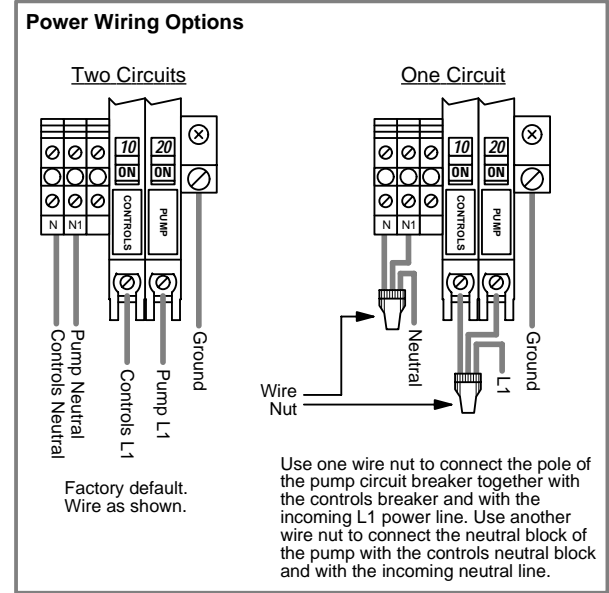
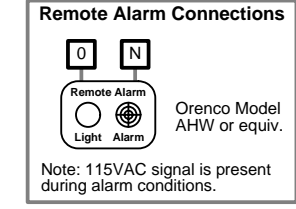
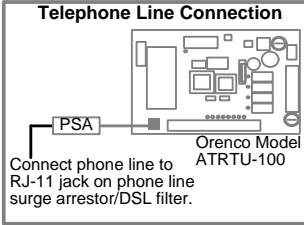

Float & Splice Box Wiring Diagram



Oreco Systems
Incorporated

814 AIRWAY AVENUE
SUTHERLIN, OREGON
97479-9012

TELEPHONE:
(541) 459-4449

FACSIMILE:
(541) 459-2884

Float Arrangement

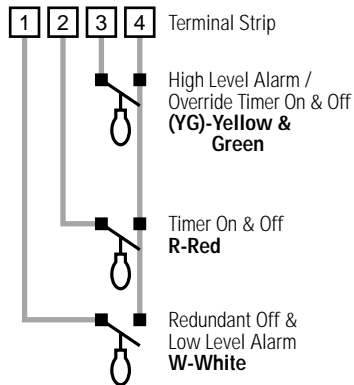

Float Types

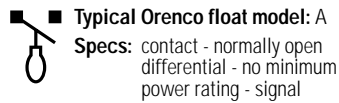

Splice Box Wiring

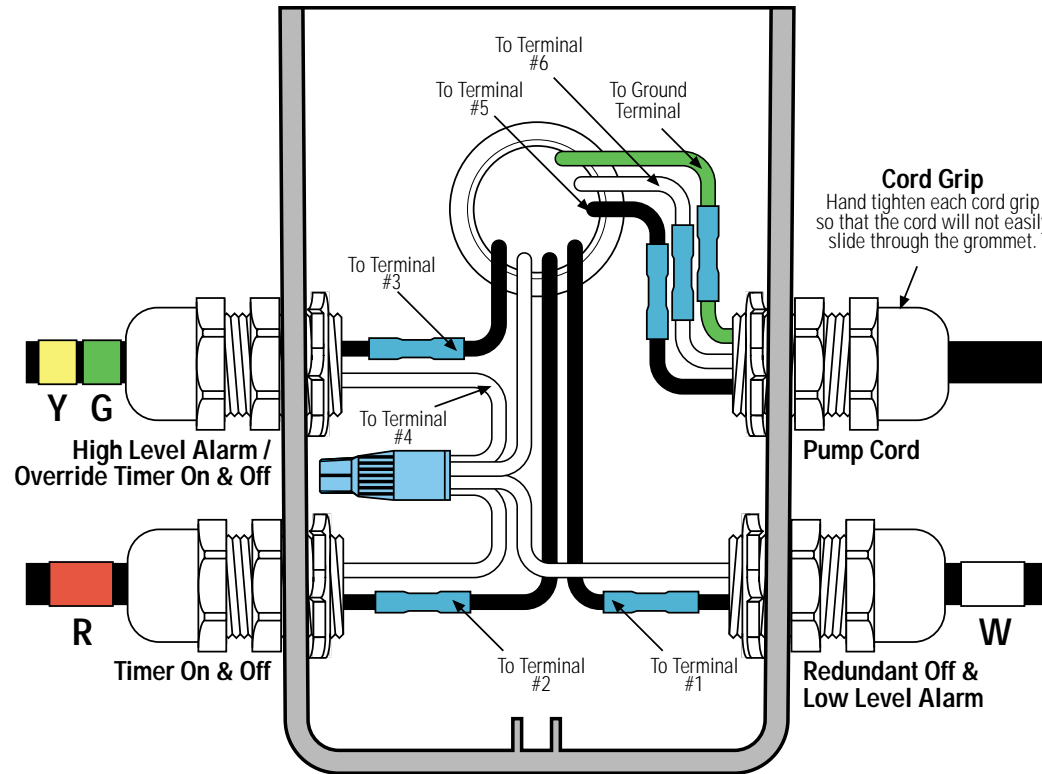

Float Tag Colors

- | | |
|------------|------------|
| Y - Yellow | R - Red |
| P - Purple | O - Orange |
| B - Blue | E - Grey |
| G - Green | W - White |

Note: Multi-function floats will have more than one marker

Key

- Black Wire
- White Wire
- Green Wire
- Waterproof Wire Nut
- Heat Shrink & Butt Connector *

Attention: Failure to follow splicing instructions will void warranty

* Refer to drawing EIN-SB-SB-1 for splicing instructions.

Control Panel Series

VCOM-S PTR0

Float Function Color Code

(YG)RW

Splice Box Model

SB4

Drawing No.

EDW-FS-S-2

EDW-FS-S-2
Rev 1.0 ©02/06/01

VCOM-S PTRO Operation

Overview

The VCOM-S PTRO telemetry-enabled panel is used for remote monitoring and control of timed dosing simplex pumping operations.

Basic control logic manages the day-to-day functionality of the control panel. The VCOM-S PTRO system discharges small amounts of treated wastewater, regularly, throughout the day (timed application with changeable dosing timers). During peak flow conditions, more aggressive timer settings are used to manage the increased demand.

Fault conditions are automatically reported to the VeriComm Monitoring System and not locally at the panel, making the system virtually invisible to the homeowner. However, if fault conditions are not responded to, or the system cannot communicate with the VeriComm Monitoring System, then local alarms may be activated.

To silence local alarms, press the “Hold-To-Silence” button until the audible alarm stops.

The procedures outlined in the remainder of this document are to verify proper installation; they should be conducted in the sequence outlined while in “Test Mode”.

Input & Output Definitions

The following inputs and outputs have been used with your control panel:

(Fig. 1)

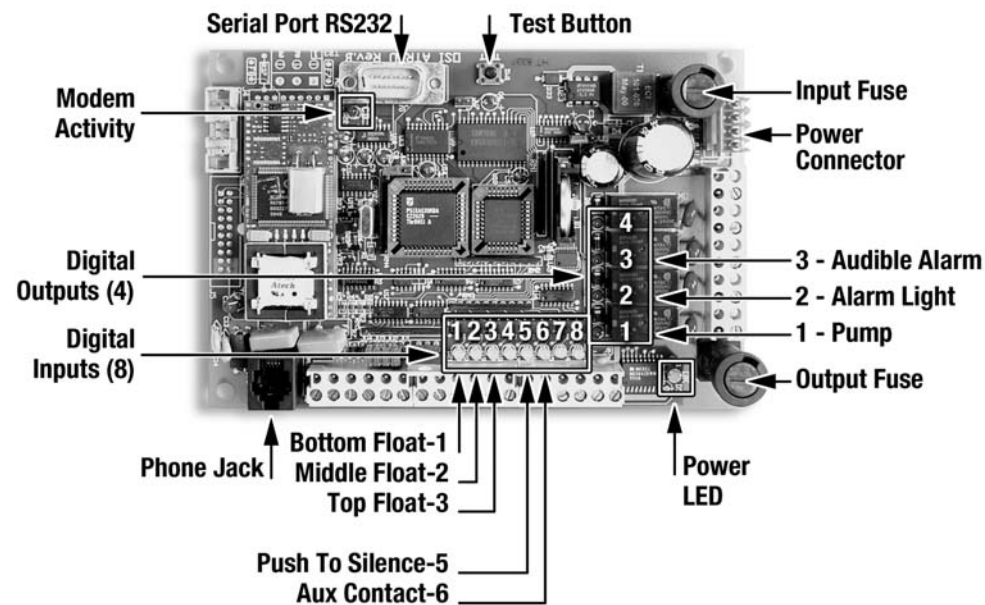

Note:

1. Digital inputs are the yellow LEDs horizontally aligned along the bottom of the controller.
2. Digital outputs are the red LEDs vertically aligned on the right side of the controller.
3. Inputs and outputs are activated by various events (e.g., Floats are activated when the float is in the up position, “Hold-To-Silence” is activated when the push button, located on the front of the panel, is pressed).

Verify System Status

- ❑ Ensure the panel installation instructions have been completed.
- ❑ Verify the circuit breakers are in the on position.
- ❑ Verify controller status. The “Power LED” located on the controller (see Fig. 1, pg. 1) will either be:
 - Blinking – indicates that the controller is operating normally, or
 - Solid Off (when power is applied) – indicates that there is a possible problem with:
 1. The input fuse on the PC board,
 2. The main fuse located inside the panel,
 3. The controls circuit breaker located inside the panel, or
 4. The incoming line voltage.

Enable Test Mode

While in test mode, the alarm light will be flashing if there is NOT an alarm condition present. During an alarm condition the alarm light will be steady.

- ❑ Hold the “Hold-To-Silence” button on the front of the panel until the audible alarm sounds (approximately 15 seconds) to enable test mode.
 - Digital input #5 should be illuminated when the button is held in.
 - When the audible alarm sounds to indicate that the panel is in test mode, release the button.

- ❑ While in test mode, the panel will operate in the following manner.
 - The "Call Home" function is disabled,
 - Local audible and visual alarms are activated as alarm conditions occur,
 - System data logs are suspended, and
 - Timer cycles are shortened.

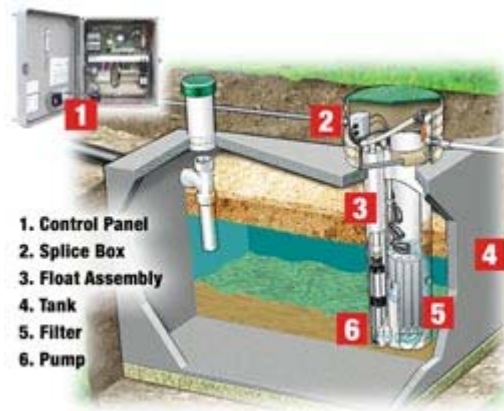

Manual Pump Test

- ❑ Verify that the pump is submerged in water before continuing. If the RO (bottom) float drops, the alarm should sound.
- ❑ Press down the spring-loaded “MAN/AUTO” switch located inside the panel. The pump should immediately activate. For verification:
 - Digital input #6 should illuminate (see Fig. 1, pg. 1), indicating that the auxiliary contact is on.
- ❑ Measure the voltage and amperage of the pump.

- Measure the voltage at the pump terminals in the panel while the pump is running. A low voltage condition could indicate that the site wiring is improperly sized.
- Using a loop ammeter, place the ammeter clamp around the loop of wire located above the pump circuit breaker. The amperage should be within the specifications of the pump.

Float Test

In test mode, the floats will function as described:

Override Timer/High Level Alarm (top float):

This float activates the override timer when lifted. The override timer controls the pump during high flow conditions. The override timer function will remain active until the set minimum number of override cycles has been completed and the float has lowered. This float also activates the alarm light (steady) and audible alarm when lifted for more than 10 seconds. Pressing and holding the illuminated “Hold-To-Silence” button on the front of the control panel will silence the audible alarm. The alarm light will remain on (steady) until the float is lowered.

Timer On & Off (middle float): This float enables the timer function when lifted. The timer function controls the pump during normal flow conditions. Note: The timer will start with its off cycle.

Redundant Off & Low Level Alarm (bottom float): This float turns off the septic tank pump when lowered. This float is a secondary off float, which will operate if the Timer On & Off float fails. This float also activates the alarm light (steady) and audible alarm. The audible alarm may be silenced by pressing the illuminated “Hold-To-Silence” button on the front of the control panel.

To perform the following test, a sufficient effluent level in the tank is required. If there is not enough effluent, turn the Pump Circuit breaker off.

To test the functionality of the floats and ensure that the panel is installed correctly, follow the steps below:

1. RO/Low Level Alarm Float Test

- ❑ Pull the float assembly out of the pump vault and position it so that all the floats are in the down position.
 - Digital inputs #1, #2, and #3 should NOT be illuminated.
 - The alarm light should be flashing on and off; the audible alarm may be sounding.
- ❑ Lift and secure the bottom float in the up position.
 - Digital input #1 should be illuminated.
 - Within a few seconds, the audible alarm should stop and the alarm light will flash.

2. Timer On & Off Float Test

- ❑ Lift and secure the middle float in the up position.
 - Digital inputs #1 and #2 should be illuminated.
 - The pump will start to cycle in approximate 36-second intervals, starting with the off cycle.
 - Digital output #1 and digital input #6 should be illuminated during the on cycle.

3. Override Timer On & Off/High Level Alarm Float Test

- ❑ Lift and secure the top float in the up position.
 - Digital inputs #1, #2, and #3 should be illuminated.
 - The pump cycles will shorten to approximate 24-second intervals.
 - The audible and visual (steady) alarms should activate (after 10 seconds). Digital outputs #2 (blinking), and #3 should illuminate.

4. Returning To Normal Cycle Time

- ❑ Drop the top float and ensure that it is now in the down position.
 - The pump should complete the minimum override cycles (default is three) and then return to its normal cycle time.
 - The pump should continue cycling as indicated by both digital output #1 and digital input #6 being illuminated during the on cycle.
 - Digital inputs #1 and #2 should remain illuminated, indicating that the bottom float is in the up position.

5. Deactivating the Pump

- ❑ Drop the middle float and ensure that it is now in the down position.
 - The pump should stop. This is indicated by digital output #1 NOT being illuminated.
 - Digital input #1 should remain illuminated; indicating that the RO (bottom) float is in the up position.
- ❑ Reinstall the float assembly into the pump vault. Ensure that the floats are free from entanglement (e.g., float cords, etc).

- ❑ Ensure that the tank has enough water to maintain the RO (bottom) float in the up position.

Communication Test

- ❑ Press and release the “Hold-To-Silence” button 15 times within a one-minute period. This instructs the panel to call the VeriComm Monitoring System.
 - A red LED (see Fig. 1, pg. 1 - Modem Activity) should illuminate, indicating that the controller has established communication with the host (this may take few minutes).
 - Once the communication session has ended, the modem will automatically disconnect.
 - If the LED does not illuminate within the specified time, verify that the phone line has a dial tone. This can be done by hooking up a phone to the line that is going into the panel.

Disable Test Mode (optional)

- ❑ The panel will automatically disable test mode and return to normal operation after 30 minutes. To disable test mode immediately, hold the “Hold-To-Silence” button on the front of the panel until the audible alarm sounds (approximately 15 seconds).
 - Digital input #5 should be illuminated when the “Hold-To-Silence” button is held in.
 - When the audible alarm sounds to indicate that the panel is no longer in test mode, release the button.

VCOM-S PTRO Reference Chart

Program: S1PTRO System 3.2

Input Functions (Yellow):

1. RO & Low Level Alarm Float
2. Timer On/Off Float
3. High Level Alarm/Override Timer
4. Not used
5. Push to Silence
6. Auxilliary Contact

Conditions for activation:

- Float in up position
- Float in up position
- Float in up position
- Pushbutton is pressed
- Motor contactor is activated

Output Functions (Red):

1. Pump
2. Alarm Light
3. Audible Alarm

Condition for activation:

- Pump is activated
- Alarm Light is activated
- Audible Alarm is activated

Test Mode:

The panel should be put in test mode during maintenance activities, troubleshooting, or panel start-up. To enable test mode, hold the silence button on the front of the panel until the audible alarm sounds (about 15 seconds). When testing is complete, the panel can be put back into normal operation by again holding the silence button until the alarm sounds, or the panel will automatically exit test mode after 30 minutes.

Forcing a Call:

To force the panel to call out, push the silence button on the front of the panel 15 times within a one minute period. Allow five minutes for the call to be initiated. Once the panel has made a successful connection, the red "CD" light on the board should be illuminated. The red light remains illuminated until the call has completed.

EIN-CP-REF-99
Rev 1.2 © 03/12/07

VCOM-S PTRO Reference Chart

Program: S1PTRO System 3.2

Input Functions (Yellow):

1. RO & Low Level Alarm Float
2. Timer On/Off Float
3. High Level Alarm/Override Timer
4. Not used
5. Push to Silence
6. Auxilliary Contact

Conditions for activation:

- Float in up position
- Float in up position
- Float in up position
- Pushbutton is pressed
- Motor contactor is activated

Output Functions (Red):

1. Pump
2. Alarm Light
3. Audible Alarm

Condition for activation:

- Pump is activated
- Alarm Light is activated
- Audible Alarm is activated

Test Mode:

The panel should be put in test mode during maintenance activities, troubleshooting, or panel start-up. To enable test mode, hold the silence button on the front of the panel until the audible alarm sounds (about 15 seconds). When testing is complete, the panel can be put back into normal operation by again holding the silence button until the alarm sounds, or the panel will automatically exit test mode after 30 minutes.

Forcing a Call:

To force the panel to call out, push the silence button on the front of the panel 15 times within a one minute period. Allow five minutes for the call to be initiated. Once the panel has made a successful connection, the red "CD" light on the board should be illuminated. The red light remains illuminated until the call has completed.

EIN-CP-REF-99
Rev 1.2 © 03/12/07

VCOM-S PTRO Reference Chart

Program: S1PTRO System 3.2

Input Functions (Yellow):

1. RO & Low Level Alarm Float
2. Timer On/Off Float
3. High Level Alarm/Override Timer
4. Not used
5. Push to Silence
6. Auxilliary Contact

Conditions for activation:

- Float in up position
- Float in up position
- Float in up position
- Pushbutton is pressed
- Motor contactor is activated

Output Functions (Red):

1. Pump
2. Alarm Light
3. Audible Alarm

Condition for activation:

- Pump is activated
- Alarm Light is activated
- Audible Alarm is activated

Test Mode:

The panel should be put in test mode during maintenance activities, troubleshooting, or panel start-up. To enable test mode, hold the silence button on the front of the panel until the audible alarm sounds (about 15 seconds). When testing is complete, the panel can be put back into normal operation by again holding the silence button until the alarm sounds, or the panel will automatically exit test mode after 30 minutes.

Forcing a Call:

To force the panel to call out, push the silence button on the front of the panel 15 times within a one minute period. Allow five minutes for the call to be initiated. Once the panel has made a successful connection, the red "CD" light on the board should be illuminated. The red light remains illuminated until the call has completed.

EIN-CP-REF-99
Rev 1.2 © 03/12/07

VCOM-S PTRO Reference Chart

Program: S1PTRO System 3.2

Input Functions (Yellow):

1. RO & Low Level Alarm Float
2. Timer On/Off Float
3. High Level Alarm/Override Timer
4. Not used
5. Push to Silence
6. Auxilliary Contact

Conditions for activation:

- Float in up position
- Float in up position
- Float in up position
- Pushbutton is pressed
- Motor contactor is activated

Output Functions (Red):

1. Pump
2. Alarm Light
3. Audible Alarm

Condition for activation:

- Pump is activated
- Alarm Light is activated
- Audible Alarm is activated

Test Mode:

The panel should be put in test mode during maintenance activities, troubleshooting, or panel start-up. To enable test mode, hold the silence button on the front of the panel until the audible alarm sounds (about 15 seconds). When testing is complete, the panel can be put back into normal operation by again holding the silence button until the alarm sounds, or the panel will automatically exit test mode after 30 minutes.

Forcing a Call:

To force the panel to call out, push the silence button on the front of the panel 15 times within a one minute period. Allow five minutes for the call to be initiated. Once the panel has made a successful connection, the red "CD" light on the board should be illuminated. The red light remains illuminated until the call has completed.

EIN-CP-REF-99
Rev 1.2 © 03/12/07